

# PBZ-300 / PBZ-500 capacitor charging power supplies

## User manual

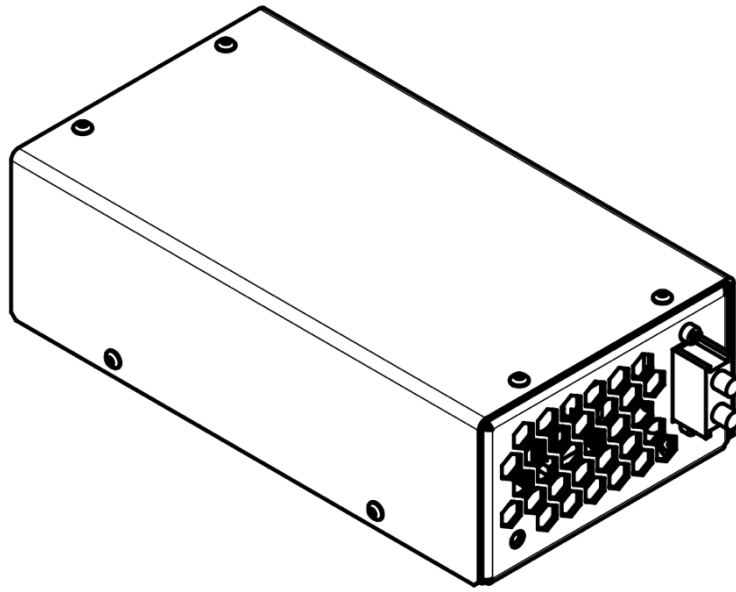

**Warning!** This equipment may be dangerous.  
Please read the entire user manual carefully before using the product.

**Important note.** The module is sensitive to reverse polarity at the output.  
If you're not sure about your application, please contact the manufacturer for details.

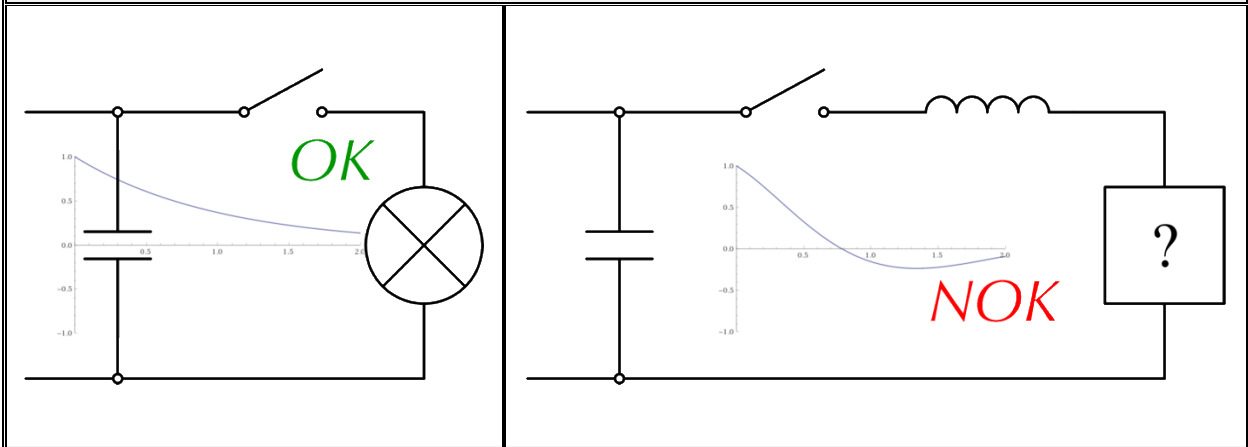

## **Table of content**

---

Table of content.....	2
Overview / Appearance .....	3
Cooling .....	4
Contents of delivery .....	4
Connectors, pins, interface signals.....	5
Safety.....	7
Operations .....	7
Specifications .....	8
Dimensions.....	10
How to order?.....	11
Appendix 1: Bench-top version PBZ-BT.....	12

## Overview / Appearance

---

PBZ-300 and PBZ-500 capacitor charging modules are high-frequency switch-mode converters, which transform low voltage DC input to a regulated high voltage DC output to charge capacitors.

The input voltage is 24V DC for PBZ-300 and 48V DC for PBZ-500. The maximum output voltage level ( $V_{MAX}$ ) could be chosen from 300V to 4000V at the moment of order. Higher output voltages are available upon request.

Output power is up to 400W and 700W for PBZ-300 and PBZ-500 respectively. By default, modules are optimized for partial discharge applications. Complete discharge modifications are available on request.

By default, all interfaces are analogue. Digital interfaces are available on request.



## **Cooling**

---

Power supplies are cooled by a built-in fan. External cooling is not required.

## **Contents of delivery**

---

By default, the following items are supplied as standard:

- PBZ-series capacitor charging power supply – 1pc
- Mating INTERFACE cable (0.5m length) – 1pc
- Mating HV OUTPUT cable (0.5m length) – 1pc

## Connectors, pins, interface signals

### INTERFACE: 13 pin mixed D-SUB connector of 13W3 type

24V DC (48V DC) power and all the control signals are to be connected here. PBZ module – plug, cable – receptacle, below is cable view.

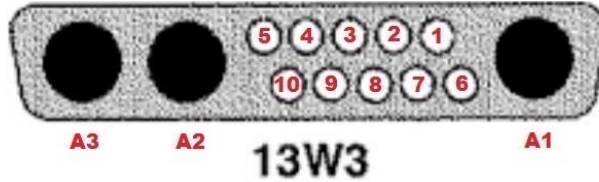

PIN (color)	DESIGNATION	DESCRIPTION
A1 (yellow/green)	GND	Module can be protectively grounded via this pin
A2 (red)	24V DC (48V DC)	DC power supply should be connected here
A3 (black)	DC RETURN	
1, 2 (transparent)	N/C	-
3 (orange)	HV Program	DC voltage applied between pins 3 and 4 sets up the output high voltage level Calibration is linear, 10V between pins 3 and 4 corresponds to $V_{MAX}$ at the output
4 (blue)	HV Program Return	Return of HV Program signal In order to improve high voltage stability HV Program Return isn't connected to the common ground of Interface
5 (green)	N/C	-
6 (violet)	Fault	5V TTL if a fault has occurred, otherwise 0V. Fault state is set in case of overheating.
7 (blue/white)	Enable	Pin 7 should be pulled to the ground to enable the output. Output is disabled while TTL high level is applied to pin 7 or pin 7 is left unconnected To use power supply in stand-alone regime, pin 7 can be short-circuited with one of Interface return pins (e.g. pin 10)
8 (white)	HV Monitor	Output voltage monitor Calibration is linear, 10V on pin 8 corresponds to $V_{MAX}$ at the output
9, 10 (black)	GND (Interface return)	Return of all Interface signals (Enable, HV Monitor, Fault) except HV Program

**Warning!** Because of safety reasons we highly recommend to use a low voltage power supply with DC output galvanically insulated from AC input (insulation strength 4000VAC, 2500VAC or 1500VAC is selected in dependence on your application).

**HV OUTPUT:** 2-pin or 3-pin proprietary connector by OEM Tech

By default, PBZ-300 (PBZ-500) is supplied with positive output polarity (P). Negative output (N), floating output (F) and bipolar output (B) are available on request. Pin layouts in dependence on modification are given in the table below:

PIN (color)	Modification			
	P	N	F	B
Number of Pins	2			3
HV- (blue)	-	-V	HV Negative	-V/2
GND (black)	GND	GND	-	GND
HV+ (red)	+V	-	HV Positive	+V/2

*“V” is output voltage amplitude*

**MOUNTING AND GROUNDING:**

The power supply should be mounted with 4pcs M4 screws (M4x10 or shorter).

**Grounding policy**

By default, all grounds of PBZ-300 / PBZ-500 (HV OUTPUT ground, 24V DC or 48V DC return and Interface return) are interconnected inside the power supply and connected to the module’s chassis.

Other grounding policies are possible on request.

**Warning!** The power supply enclosure should be protectively grounded using provided M4 grounding thread.

## Safety

---

**Warning!** This equipment produces high voltages that can be very dangerous.  
Be careful around the equipment.

Assemble the entire setup before powering up the device.

- The power supply enclosure must be protectively grounded using the provided grounding stud.
- Use a low voltage power supply with DC output galvanically insulated from AC input (insulation strength 4000VAC, 2500VAC or 1500VAC is selected in dependence on your application).
- Do not connect / disconnect output cables when the module is turned on.
- Do not operate with load disconnected.
- Avoid casual contacts of personnel with output cables and with the load.
- Do not turn the power supply on if it was already damaged with water, chemicals, mechanical or electrical shock.
- Do not attempt to repair the power supply yourself, there are no user serviceable parts inside.

## Operations

---

- 1 Ensure 24V DC (48V DC) power supply is off
- 2 Connect the PBZ-300 (PBZ-500) to the load and to the 24V DC (48V DC) power supply. Do not apply DC power until the setup is completely assembled
- 3 *Disable* the PBZ-300 (PBZ-500) (pin 7 of Interface)
- 4 Set HV Program to 0V (pins 3 and 4 of Interface)
- 5 Apply 24V DC (48V DC) power to the PBZ-300 (PBZ-500)
- 6 Set HV Program to the desired value (pins 3 and 4 of Interface)
- 7 *Enable* the PBZ-300 (pin 7 of Interface)

## Specifications

---

### ELECTRICAL

	<b>PBZ-300</b>	<b>PBZ-500</b>
<b>Input</b>		
Input voltage (DC)	24 V	48 V
Input current	<20 A	<18 A
<b>HV Output</b>		
Output polarity	Positive by default (negative polarity, floating and bipolar outputs are available on request)	
Maximum output voltage ( $V_{MAX}$ )	300V, 500V, 700V, 1000V, 2000V, 4000V or other (user selectable in 300V-4000V range)	
Nominal output power (complete discharge modifications, can be achieved in regime 0-100% of $V_{MAX}$ , rated input voltage, 25 °C)	300 J/s	500 J/s
Nominal output power (partial discharge modifications, can be achieved in regime 70-100% of $V_{MAX}$ , rated input voltage, 25 °C)	400 W	700 W
Output power deratings	Output power is derated when: <ul style="list-style-type: none"> <li>- operating voltage is lower than 70% of <math>V_{MAX}</math> (PD modifications)</li> <li>- operating voltage is lower than <math>V_{MAX}</math> (CD modifications)</li> <li>- ambient temperature is higher than 25 °C</li> <li>- input voltage is below minimum rated voltage</li> </ul>	
Voltage stability	<0.5%	
Voltage ripple/hysteresis	<0.5%	
Efficiency	More than 85%	

<b>Protections</b>	From overheating
<b>Environment</b>	
Operation temperature	+10...+40 °C
Storage temperature	-20...+60 °C
Humidity	<90%, non-condensing

### MECHANICAL

Size (LxWxH)	See dimensional drawing below
Weight	<1.0 kg

# Dimensions

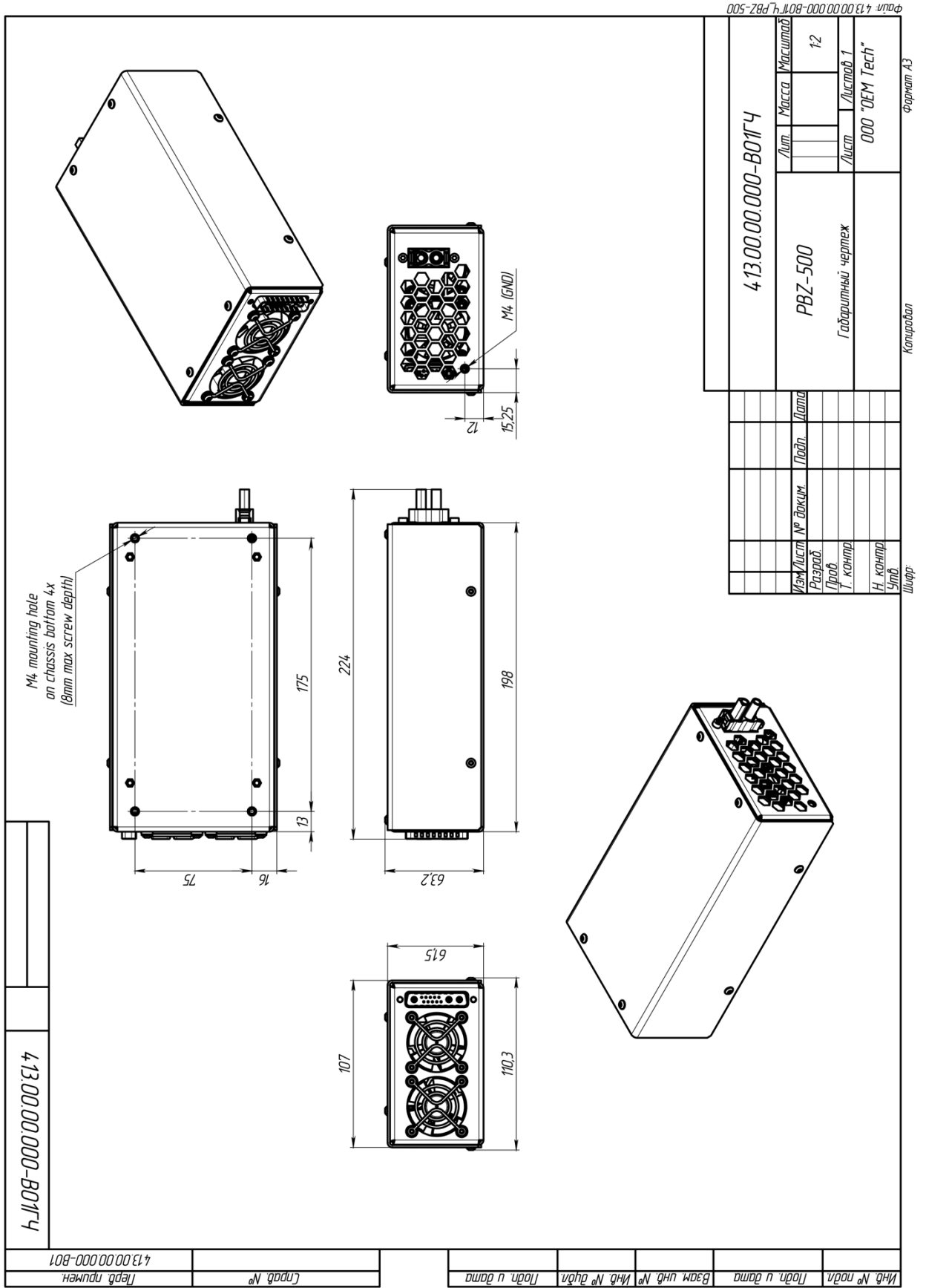

## How to order?

---

PBZ-[BT]-300-XXXX-YY-Z or PBZ-[BT]-500-XXXX-YY-Z, where:

- BT means bench-top version (option)
- XXXX means maximum output voltage – user selectable from 300V to 4000V (300V, 500V, 700V, 1000V, 2000V, 4000V are the most standard modifications)
- YY means discharge type modification – CD for complete discharge modification, PD for partial discharge modification; if YY is not specified PD modification will be supplied
- Z means output polarity – P for positive, N for negative, F for floating output, B for bipolar output (three leads output). By default, modifications with positive output are supplied

Examples:

P/n	Description
PBZ-300-500V-PD-P	Embedded version, 24V DC input Maximum output voltage 500V Partial discharge modification Maximum output power 400W Positive output polarity
PBZ-500-4000V-CD	Embedded version, 48V DC input Maximum output voltage 4kV Complete discharge modification Maximum output power 500J/s Positive output polarity
PBZ-BT-300-4000V-CD-B	Bench-top version, 100-240V AC input Maximum output voltage 4kV Complete discharge modification Maximum output power 300J/s Bipolar output

Other  $V_{MAX}$  are available on request.

## **Appendix 1: Bench-top version PBZ-BT**

---

Bench-top version of PBZ-300 with 100-240VAC input is also available.

Bench-top version of PBZ-500 with 100-240VAC input is available on request.

